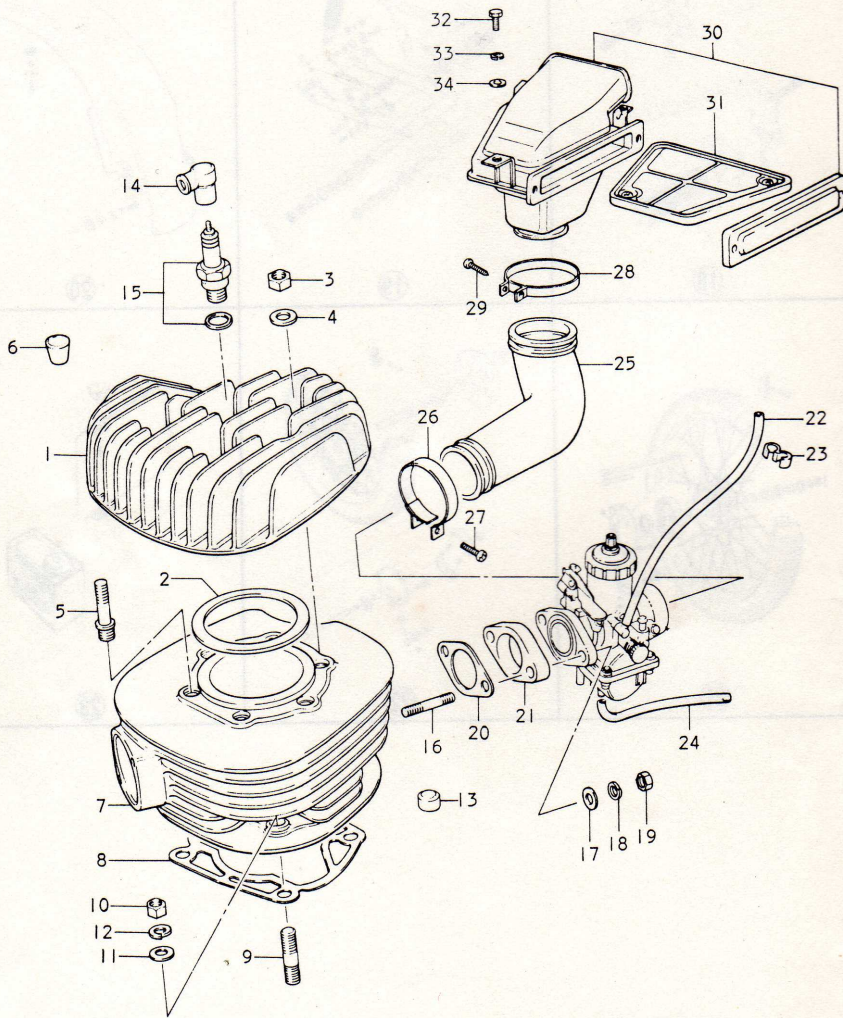

FIG.1 CYLINDER - AIR CLEANER



RL250

FIG.1 CYLINDER - AIR CLEANER

Ref.No.	Part No.	Description	Q'ty		Remarks
			L	M	
	11400-30830	GASKET SET	1	-	} to 11400-30831 -OPT
	11400-30831	GASKET SET	-	1	
1	11111-38001	CYLINDER HEAD	1	1	
2	11141-16300	GASKET, cylinder head	1	1	
3	09140-08005	NUT	6	6	
4	08322-21088	WASHER	6	6	
5	09108-08018	STUD BOLT	6	6	
6	11151-25000	RUBBER PAD, cylinder head	8	9	
7	11210-38000	CYLINDER	1	1	
8	11241-30000	GASKET, cylinder	1	1	
9	01421-10308	STUD BOLT	4	4	
10	08312-11108	NUT	4	4	
11	08322-11108	WASHER	4	4	
12	08321-21108	LOCK WASHER	4	4	
13	11252-38000	RUBBER PAD, cylinder	16	16	
14	33510-28300	CAP, spark plug	1	1	
15	09482-00055	SPARK PLUG ASSY	1	1	B-7ES, NGK
16	01421-08358	STUD BOLT	2	2	
17	08322-11088	WASHER	2	2	
18	08321-21088	LOCK WASHER	2	2	
19	08312-11088	NUT	2	2	
20	13125-30000	GASKET, carburetor	1	1	
21	13129-30000	INSURATOR, carburetor	1	1	
22	09343-03009	HOSE, carburetor air vent	1	1	
23	09408-00005	CLIP	1	1	
24	09343-03013	HOSE, carburetor over flow	1	1	

RL250

FIG.1 CYLINDER - AIR CLEANER

Ref.No.	Part No.	Description	Q'ty		Remarks
			L	M	
25-1	13881-38000	HOSE, carburetor inlet	1	-	to 13881-38001
25-2	13881-38001	HOSE, carburetor inlet	-	1	
26	09402-00246	CLAMP	1	1	
27	02111-05207	SCREW	1	1	
28	09402-58304	CLAMP	1	1	
29	03211-04258	SCREW	1	1	
30	13700-38610	CLEANER ASSY, air	1	1	
31	13780-38010	FILTER	1	1	
32-1	01112-06168	BOLT	2	-	
32-2	01112-06128	BOLT	-	2	
33	08321-21068	LOCK WASHER	2	2	
34	08322-21068	WASHER	2	2	

RL250